

# Power System Selectivity: The Basics of Protective Coordination



by Gary H. Fox, PE  
GE Specification Engineer

The intent of this article is to provide a brief primer about the essence of coordinating the basic protective components of the electrical power system, including circuit breakers, fuses and protective relays, and to enable the reader to review a plot of time-current curves and evaluate several key concerns:

- How well do the devices work with each other?
- Will a minimal amount of the power system be lost by a fault?
- How well are the power system components protected?
- Could the chosen ratings and settings cause nuisance trips?

contend with. If you lean toward system availability, you might increase the equipment damage to undesirable levels.

## The Objectives of Protection

Determining the protective devices for a power system and their settings usually puts two competing goals against each other. On the one hand you want the system available for use 100 percent of the time. To this extreme end all power outages, whether due to maintenance or failures, are to be avoided. You would want the protective device ratings and settings to be as high as possible, and these settings would be further desensitized by a considerable time delay, so that extra time is allowed before the circuit is tripped. On the other hand there is a concern for the protection of the load and system components. The degree of damage from a short-circuit fault is proportional to the amount of time that fault persists and the square of the current that flows. The energy released can literally be breathtaking. So standards and good engineering practices lean toward protecting electrical equipment. Protection is enhanced by using devices that are sensitive to the minimal amount of fault current that might flow, and the device should isolate the fault as quickly as possible. You can see that if you err on the side of protection, you may have several outages to

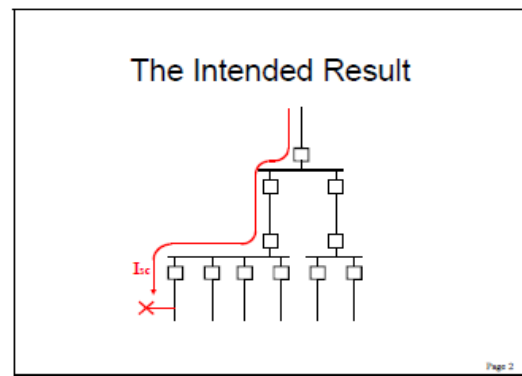

Figure 1 — An example of short circuit flow in a radial system

## The Definition of Selectivity

A power system where these competing goals are in balance has *selectivity* as a characteristic. What is *selectivity*? Complete selectivity means that the protective devices will minimize the effect of a short circuit or other undesirable event on the power system. The amount of the power system that must be shut down in response to the event is kept to the absolute minimum. For the purposes of this article, we will focus on short circuits, also referred to as *faults*. While several devices may respond to the fault, we want the first protective device in the path leading toward the power source to operate and clear the fault. If the next one beyond that one were to open, then other loads not fed by the unfaulted circuit might be turned off unnecessarily. Figure 1 is an example of a short circuit in a radial system where four circuit breakers could be sensing the current flow caused by the short circuit. The circuit breaker immediately upstream of the fault is the most desirable breaker for isolating this fault.

Selectivity can be achieved with devices that are inherently selective. That is, they operate only on faults within their zone of protection and do not ordinarily sense faults outside that zone. When a fault occurs inside the zone, the device typically responds instantaneously and trips breakers on the edge of the zone that are associated with short circuit contributors into the zone. If a fault occurs outside the zone, fault current may flow through the zone but the device will not operate for this *through-fault*. Examples of inherently selective systems are current differential relays (typically applied on buses, motors, generators, and transformers), pilot wire relays, and transformer sudden pressure relays. While these devices offer the best in circuit protection, they can add significant cost to the power system. These protective devices tend to be much more expensive than overcurrent devices, but the cost may be worthwhile if it reduces the amount of damage to a critical piece of equipment or reduces the amount of lost production resulting from a fault. For this reason they tend to be used sparingly, usually when the protected equipment is critical, or if an extended outage to repair the system would cause significant economic loss.

In most other cases, a simple overcurrent device in the form of a circuit breaker, fuse, or overcurrent relay is used. In a properly designed power system, these devices can provide selective coordination under most circumstances at a reasonable cost. They are currently the workhorses of electrical protection.

When evaluating and comparing time-current curves, you should keep in mind the following. It is assumed that the fault current is constant up until the time that the fault is cleared; the graphical evaluation of curves may not necessarily reflect the true characteristics when the fault current is varying. In the real world, the fault may vary depending on the contact area of the fault, the degree of arcing that is occurring, and a number of other factors. In most cases, the fault current tends to escalate upwards from its initial value, but this is not always the case.

In the presence of a current of varying magnitude, devices that use different monitoring or time delay techniques may not react in the same way, especially if the current falls below the pickup setting of the device. For example, consider what may happen when a circuit breaker with a bimetal element is responding to the same current as an induction disk time overcurrent relay. If the current drops below their respective pickup settings momentarily, different things happen within the each device. In the circuit breaker, the bimetal may cool slightly, but if the current restores itself quickly, the bimetal will continue to heat and will probably trip out in much the same time as the curve indicates. In the case of the induction disk relay, the disk will turn backward toward its reset position. Whether it gets all the way back to this position depends on how low and for how long the current drops. The disk could turn backwards quite a ways and start up again in a different part of the delay cycle in comparison to the breaker. The relay then may trip out at a longer time delay than the breaker as indicated by the curves for this varying fault condition.

In solid-state devices, the device may have some memory of fault currents that have occurred so that the device can trip in response to sporadic or sputtering currents. This is used extensively in ground fault trip devices as a sputtering ground fault can alternate from above the pickup value to below pickup. When you compare the devices that have memory with those that do not, remember that the ones with memory would trip out sooner for a sputtering type of fault, while those without memory may not trip at all.

In determining ratings and settings for circuit breakers and fuses, there are two settings that can be used to create selectivity. These are called the pickup and the time delay. The pickup of a device is the minimum level of current at which the device will initiate a trip or a fuse may blow. In circuit breakers and fuses, the thermal or long-time pickup is usually about the same as the current rating of the device. In adjustable circuit breakers and protective relays, it may be possible to set the pickup across a broad range of current values. This may be particularly desirable in situations where the user wants to keep the number of spare devices to a minimum, and he chooses to use a breaker whose frame rating and trip device allow it to be used for a number of different circuits.

Time delay is an intentional delay in trip operation after the device has sensed that the current has exceeded the pickup value. Usually, time delays are used to provide time for another overcurrent device to operate and clear the fault. It may also be used to allow for a normal temporary overcurrent condition to pass or to allow the condition to clear itself. An example of normally occurring temporary overcurrents are motor starting currents and transformer inrush currents. In these instances, the inrush currents exceed the pickup of overload devices protecting the transformer or motor, but the time delay of the overload should allow sufficient time for the inrush current to flow and prevents an unnecessary trip from occurring.

## Selectivity Rule No. 1: The Use of Pickup Settings

Figure 2 shows how curves with different pickup values can be selective and illustrates the first rule of selectivity, which is, two devices are selective if the downstream device curve is located to the left of the upstream device curve. This can only happen when the pickup setting of the downstream device is set to a current that is less than the pickup setting of the upstream device. Note that the convention for time current curves is to end the rightmost portion of the curve at the maximum fault current that the device will sense in the power system in which it is applied. Increasing the pickup setting shifts the curve toward the right of the graph. In the example, for any current up to the maximum fault current of the left-hand curve, the curve on the left will trip out before the curve on the right. Currents that exceed the maximum current of the left-hand curve are not physically possible and are sensed only by the device represented by the right-hand curve.

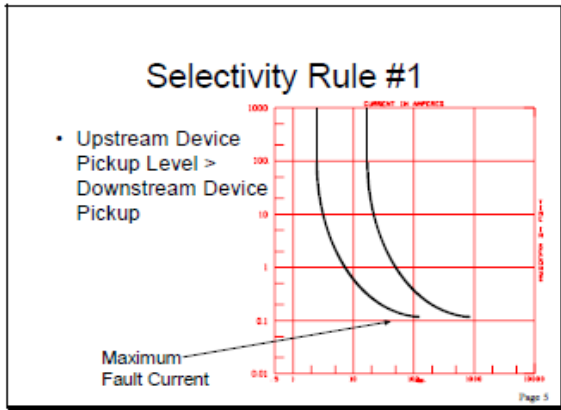

Figure 2 — Creating selectivity by proper selection of pickup settings

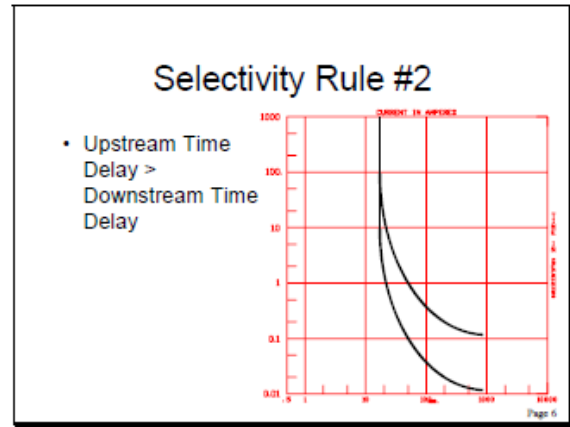

Figure 3 — Creating selectivity by proper selection of delay settings

## Selectivity Rule No. 2: The Use of Delay Settings

Figure 3 shows how varying time delays can provide selectivity. Increasing the time delay shifts the curve upwards on the graph. Note that for all currents within the range of the curves, the curve on the bottom will trip out before the curve above it. So the second rule of selectivity is that the downstream device must be placed lower on the graph than the upstream device for the two devices to operate selectively.

## Selectivity and Instantaneous Trips

All molded-case circuit breakers listed under Underwriter Laboratories (UL) standard 489 must have an instantaneous element to sense severe short circuits. The pickup of instantaneous trips is typically on the order of 3 times to 10 times the current rating or setting of the circuit breaker. When the current exceeds the pickup of the instantaneous element, the breaker immediately trips. In this case, the definition of instantaneous is *without intentional delay*.

Severe short circuits that involve more than two circuit breakers in series may exceed the instantaneous pickup setting of all the breakers. When this happens, one of the following will occur:

- Multiple breakers may trip
- Only one breaker may trip, and it may not necessarily be the lowest rated breaker

Predicting whether one breaker or another will trip is not always possible. The older thermal magnetic breakers are nearly impossible to predict while some of the newer solid-state trip units can be counted on to trip out quicker than an older thermal magnetic unit. However there are circuit breakers being designed today that have a current limiting effect that allows them to trip out and prevent a higher rated breaker on their line side from tripping. It may

be possible in the future to predict the behavior of breaker instantaneous trips or to get manufacturer-supplied information of selective breaker combinations.

Protective relays may also have an instantaneous setting that can cause the same sort of complications and compromises as those of low voltage breakers. However, in protective relays, the protection engineer usually has a choice to use or not use the instantaneous trip on overcurrent relays (ANSI device number 50). The relay model may have the instantaneous element omitted. In models with the instantaneous element, the instantaneous trip is provided in the form of separate contact that is wired in parallel with the time overcurrent trip contact. If the instantaneous trip is not desired, the wiring of the trip contacts is simply removed (when this is done, it is a good idea to note this somehow at the relay so an operator will know that the instantaneous trip on the relay is inactive). In the more advanced electronic types, instantaneous blocking schemes can be used to allow relays on mains to provide rapid response to severe bus faults. When the protective relays on the feeders sense a short circuit, they send a blocking signal to the mains and block the main instantaneous from operating. If the fault is on the bus that supplies the feeders, the feeders cannot sense that fault and send no blocking signal. The instantaneous trip on the main remains active and can trip out the main breaker.

## Putting It All Together: Identifying Complete Selectivity

Determining the selectivity of a set of time-current curves is quite easy. The curves should line up from left to right or bottom to top in the sequence of load to source. There should be no overlapping of the curves nor should they cross each other. There should be sufficient space separation between the curves (more on this later). The curves can also indicate whether upstream devices provide backup protection. This occurs when the left-most portion of the backup device extends over into the range of currents of the preferred device.

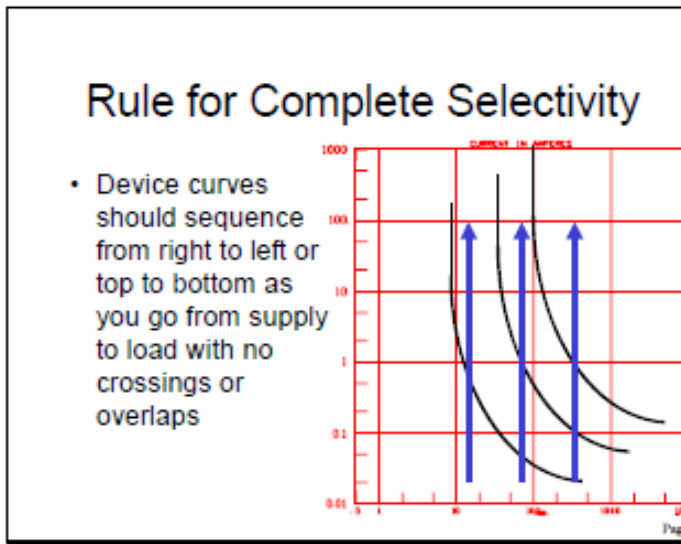

Figure 4 — Identifying complete selectivity

In Figure 4, the devices line up as recommended. Note that as you follow the three fault current levels through time, the device closest to the load will finish its time delay first and trip before the other breakers. If the device closest to the load fails to operate, the next device upstream will trip after the additional time delay indicated and before the other remaining device.

Figure 5 offers an example of a system that is not selective at certain current levels. Three fault locations and corresponding current levels are shown using the colored symbols and arrows. Each breaker shown is in a switchboard or panel that can contain other feeders or branches, so the tripping of either breaker 1 or breaker 2 will isolate much more than the single load shown in the single-line diagram (Fig. 1).

Let us begin with the fault current signified by the green arrow. The fault location causes current flow through all three breakers. But the current magnitude is high enough to cause only breakers 1 and 3 to pickup. Breaker 3 will trip first and isolate the fault so the system appears to be selective. However, notice that in a backup situation where breaker 3 fails to trip, breaker 1 will trip rather than breaker 2, and result in an outage to more of the power system than necessary.

The fault shown by the blue arrow is located on the line side of breaker 3, so this breaker will have no current flow through it. Breakers 1 and 2 will sense this fault. Because of the crossing of the curves of breakers 1 and 2, breaker 1 will trip first for this fault, which is undesirable since it would be isolating more of the system than really necessary.

The fault shown by the yellow arrow has a higher current and is also sensed by breakers 1 and 2. In this case, the current level is high enough to pass through the curves where breakers 1 and 2 are selective, to the right of the intersection of the curves. The breakers will respond selectively.

The evaluation of time-current curves involves more than just the determination of selectivity. They can also be used to avoid the nuisance tripping of loads. This is common for

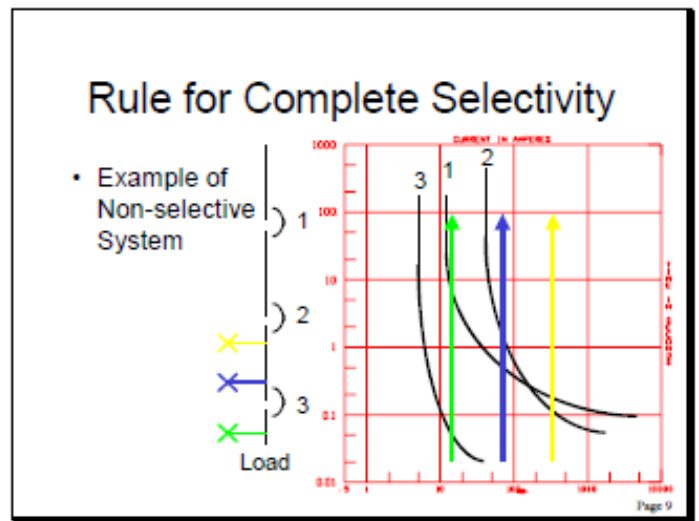

Figure 5 — An example of a non-selective system

those loads that can cause temporary overload conditions. These loads (and the normal overload condition) include motors (starting inrush), motor drives (high currents due to acceleration), and transformers (inrush current from energization). The protective device needs to have settings that allow for this condition to temporarily persist without tripping. These conditions may last several seconds as is the case for motor starting, or they may be quite brief as in the case of transformer inrush currents. These load characteristics can be plotted on the time current graph and the curve of the circuit breaker on the line side of the load causing the inrush should be located to the right or above the inrush characteristic. If this is not the case, nuisance tripping will occur. An example of a properly plotted motor and transformer inrush will follow later.

Time-current curves can also be used to ensure that distribution system components are properly protected from the secondary effects of fault currents. Remember that the unfaulted components must be able carry the fault current up until the time it is cleared without sustaining damage to themselves. The time current curve can illustrate those qualities. Cable, transformer, and busway withstand curves are commonly plotted on time current graphs and used to assure that the protection system will prevent damage from faults flowing through those conductors (also called *through-faults*). The component damage curves may also be called a withstand curve, as they indicate the level of current and the amount of time that a component can sustain a potentially damaging current without overheating and being damaged.

For withstand curves, we want the opposite of what was described for nuisance tripping to happen. For these curves, we want the protective device to clear the fault before the time indicated by the withstand curve. We want the circuit breaker curve to be entirely to the left or below the withstand curve of the component it is protecting. Any overlap

or crossing of the circuit breaker curve with the withstand curve means that there is a range of currents for which that component is not adequately protected. This occurs often in the application of transformer overcurrent protection. Typically, the primary circuit breaker or fuse cannot protect the transformer adequately for overload conditions. The secondary main device usually adequately protects the lower range of overcurrents. When the secondary main is close-coupled to the transformer, the risk of through-faults sensed by the primary device alone is very low.

Complete selectivity is achievable, but it usually results in higher cost because only the most robust equipment and/or advanced protection will have the necessary features and characteristics. In low-voltage systems, complete selectivity using time-overcurrent protection usually requires the use of the power circuit breaker, which is designed to carry short circuits for up to 30 cycles, rather than 3-cycle rated molded-case breakers. Or a selective system may require the use of special inherently selective schemes. A well-known example of an inherently selective device is the current differential relay which measures the currents entering and exiting each circuit associated with its protective zone. If the currents entering the zone do not equal the currents exiting, then a short circuit must exist and the monitoring device can react instantaneously to this situation. Current differential protection is more costly than time-overcurrent protection because the relaying usually needs to be more than just an instantaneous element to be effective and reliable. The additional wiring and current transformers needed to monitor all the incoming and outgoing connections adds to the cost of the system, or the distance between protective devices outlining the zone may make it unfeasible to apply differential protection. However, the length limitation is becoming less of an obstacle with the application of high-speed digital communications over fiber optic networks. Also, bus differential systems in low-voltage switchgear have become more feasible and cost-effective through the development of single-processor type protection and control. [1]

Owners are seldom willing to pay the additional cost for complete selectivity. Economic feasibility usually demands that the additional cost must offset the economic effects of an undesirable outcome. An unnecessary outage of undamaged portions of the system might result in intolerable loss of production. This can occur in silicon chip fabrication facilities or petrochemical plants. An unnecessary outage might even place lives at risk as in the case of health care and process industries. These and similar facilities are the places where investment is made in premium distribution equipment and protective systems. In other applications, as in a school or an office building, these economic pressures do not exist and the investment is not made. For these cases, less than perfect selectivity is tolerable. Compromises are made to achieve the goal of a cost effective system. Knowing how to obtain the most from a power system protection system is learned mainly through experience.

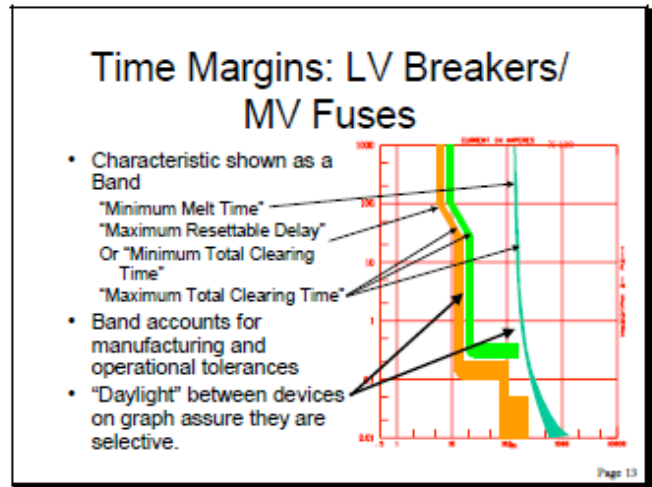

Figure 6 — Overcurrent device curves with minimum and maximum clearing times

## Identifying Selectivity of Fuses and Low-Voltage Circuit Breakers

The evaluation of selectivity among low voltage devices is straightforward once you understand the limits that the curves define. Most low-voltage device time characteristics are shown as a band (see Figure 6). The left-most boundary may be referred to in several different ways. In fuses, this limit is called the minimum melt time and is the point at which the fusible element begins to melt. With circuit breakers, this limit may be expressed as either the *Maximum Resettable Delay* or the *Minimum Total Clearing Time*. The maximum resettable delay is the maximum time that a given current may persist without causing the breaker to trip. A current can persist right up to the time defined by the curve with assurance that the breaker will not trip. The minimum total clearing time is the minimum amount of time that can be expected to clear the fault. It should be understood that at some time prior to this, the circuit breaker mechanism had been committed toward isolating the current. The time for the mechanism to operate and extinguish the arc inside the breaker has to occur before the minimum total clearing time. A time margin must be allowed to account for this time.

The boundary to the right of the band is called the *Maximum Total Clearing Time*. At this boundary, the manufacturer assures us that the mechanism has acted and the fault current has been stopped completely. Manufacturing tolerances are accounted for by this limit, as well as all tolerances that may be affected by the standard service conditions (these are usually noted on the device's published time-current curve).

When comparing one curve band to another, the devices are considered to be selective as long as the curves do not overlap anywhere and the source side device is above or to the right of the load side device. There should be a gap between the maximum total clearing time of the load-side device and the maximum resettable delay or minimum melt time of the source side device. So long as there is “daylight” between the curves (meaning they don’t touch each other or overlap), selectivity should be achieved.

The curve represents the ideal operation of the relay. The manufacturing tolerances are not reflected in the curve. To coordinate an overcurrent relay with other protective devices, a minimum time margin must exist between the curves.

This time margin can account for several things including the circuit breaker clearing time, the tolerances of the circuit breaker and the relay, maintenance practices, and the effects of mild current transformer saturation.

A time margin of 0.35 second is generally used in most circumstances involving induction disk type relays. The 0.35 second includes 0.08 second for circuit breaker clearing time (5 cycles), 0.17 second safety factor to account for maintenance practices and current transformer saturation, and 0.1 second for relay overtravel. Relay overtravel is the extra motion due to inertia that the induction disk will make after the current ceases.

Reduced time margins are used in the following circumstances. If induction disk relays are calibrated annually, a 0.05 second deduction can be applied. Deduct 0.05 second when solid-state-relays are applied since they typically do not fall out of calibration as easily as induction-disk relays. Also, solid-state relays have negligible overtravel, so 0.1 sec can be deducted for this. Relay overtravel also doesn’t apply when the load side device is not an induction disk relay.

The following example illustrates the concepts that have been discussed. This example will include an individual motor and its protection, the protection of the motor control center, the distribution switchgear, the substation transformer, and the high voltage devices that protect it.

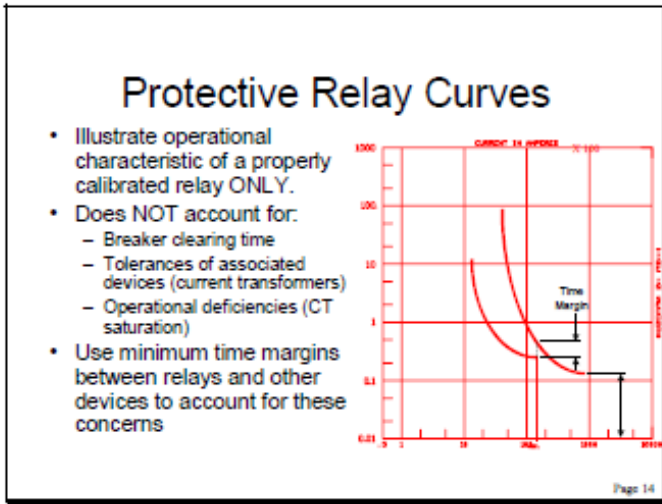

Figure 7 — Protective relay time margins

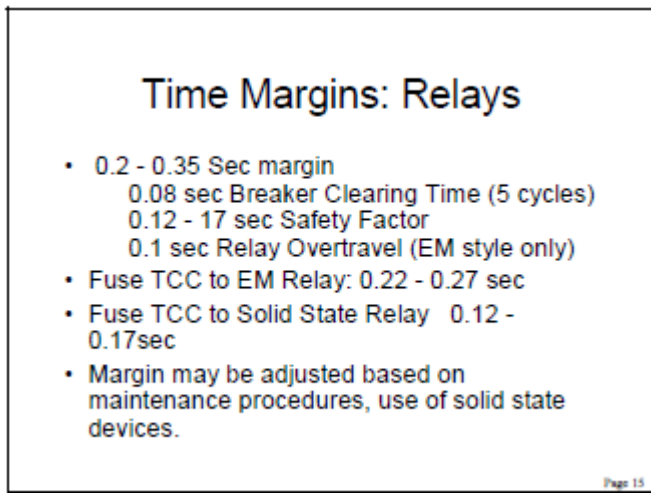

Figure 8 — Recommended relay time margins

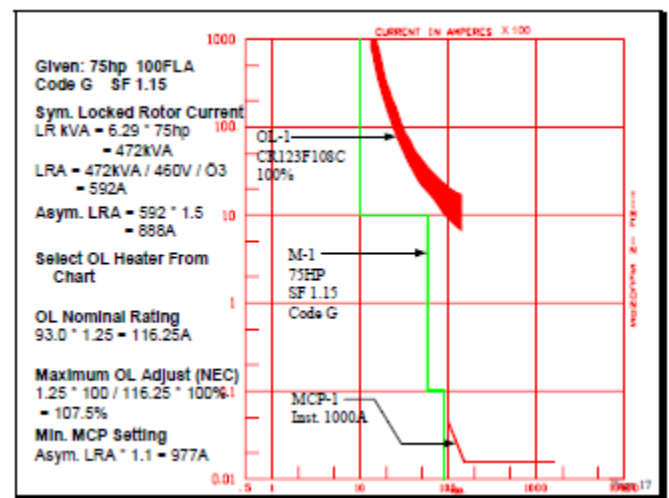

Figure 9 — A motor load and its protection

## Selectivity and Overcurrent Relays

Protective relay curves cannot be used in the same way as low-voltage circuit breaker curves or fuse curves. The protective relay curve only represents the action of a calibrated relay. It does not account for the actions of the associated circuit breaker or the accuracy of the current transformers that connect the relay to the circuit that it is monitoring.

Optimized protective device settings are best obtained by beginning at the load and working your way toward the source. This allows protective settings to be as sensitive as possible without sacrificing selective operation. Let us begin with the load of this example, a 75 horsepower motor with a service factor of 1.15, and a locked rotor kVA code G.

The motor load characteristic consists of three basic parts. The continuous load of the motor, the starting current, and the maximum asymmetrical starting current. The continuous-current rating of the motor is obtained from the motor nameplate. The locked rotor current is obtained by calculating the current from the locked rotor kVA represented by the code letter found on the motor nameplate. Since the locked rotor code represents a range of values, the maximum value in the range is typically applied. 6.29 kVA/hp is the maximum locked rotor kVA for code G.

For a three-phase motor the equation  $I = \text{kVA} / \sqrt{3} / \text{Volt}_{L-L}$  is applied. The motor nameplate voltage of 460 V is used instead of the nominal system voltage of 480 V to obtain conservative results.

The starting current may be asymmetrical depending on whether the motor is started near a zero-crossing point in the voltage cycle. The asymmetry can persist for up to 0.1 second. For low voltage motors it is common procedure to use a factor of 1.5 to calculate the maximum asymmetrical current from the locked rotor current.

Lines are plotted for each of these values. The asymmetrical current is plotted from 0.01 second to 0.10 second. The locked rotor current is plotted from 0.1 second to the duration for the motor to accelerate to its top speed (a conservative value of 10 seconds is commonly used). The continuous current line is drawn from this point up to the top of the graph at 1000 seconds.

Horizontal lines are used to tie the three vertical lines together. Sophisticated curves can be drawn where the three lines are tied together using curves that more accurately reflect the current during motor acceleration.

The motor overload protection can be plotted next. The appropriate overload heater is usually found in a table. When selecting and plotting the heater curve, you want the overload device curve to allow the motor to accelerate to full speed, so the overload curve needs to be above or to the right of the motor curve.

The motor short-circuit protection must allow the starting current to flow, so its curve needs to be to the right of the motor curve. Instantaneous protection at this level causes no complications because there are no other instantaneous devices downstream, just the load itself. In determining the instantaneous setting of the short circuit protection, be sure to allow for the tolerances of the setting if this is not indicated by a band.

The settings of the motor control center feeder have to take into account the total continuous load of the motor control center and the maximum inrush current that this feeder may have. It must also coordinate with all protective devices in the motor control center. If there is no main breaker, our only concern is the devices protecting the largest motor. This is because the protective settings for the largest motor will be the ones with the highest pickup values for both overload and short circuit protection. If we set the feeder settings to coordinate with the largest motor, then those settings should coordinate with the protective devices of all the other motors which would show up on the graph as farther to the left than that of the largest motor's devices.

For this example, we'll assume that the 75 horsepower motor is the largest one in this motor group, and the feeder breaker settings can be coordinated to the curves we have already plotted.

The feeder breaker has a fully adjustable trip device. It has settings for the long time current setting, long-time delay, short-time and its corresponding delay setting, and instantaneous. The feeder breaker may also have a ground fault function; however, it is customary to show a separate plot for ground fault devices since they seldom can coordinate with phase overcurrent settings. Each of the phase current settings must coordinate with either the maximum load characteristic or the maximum protective device characteristic, whichever is greater.

The plot of the inrush current of the motor control center is a combination of the total load current plus the inrush of the largest motor, assuming the motors are started sequentially and not simultaneously. The total load current should be the full load current of all the motors expected to be in operation simultaneously. This is plotted from the top of the graph down to the starting current time of the largest motor. The total inrush combines the locked rotor current of the largest motor with the full load current of all the other motors expected to be in operation. A conservative calculation would add the full load current of all the other connected motors to the locked rotor current of the largest motor. This combination load profile is plotted similarly to the individual motor load profile.

The sequence in determining circuit breaker settings is somewhat important. In most cases, the short circuit functions are a function of the current setting. The current setting needs to be plotted first so that you can then determine the range of settings available for the short time (if available) and/or instantaneous functions.

The motor control center bus and the feeder cable should have approximately the same ampacity. The current setting of the feeder breaker is usually set to the same value as the feeder ampacity which is the current rating of the feeder cable or the motor control center bus, whichever is less. This is the maximum setting that the NEC permits and allows for future expansion if the feeder is not already fully loaded. A long-time delay is then selected which places its band so that there is daylight between its minimum tolerance limit and the total clearing time of the overload curve.

The short time setting of the feeder must coordinate with the maximum inrush current of the motor control center and the highest set short-circuit device in the motor control center. In this case, the motor circuit protector setting of the largest motor has the highest characteristic. The correct short time setting is the one that allows the short time curve to be completely to the right of the instantaneous setting of the motor circuit protector. The short time delay is the lowest possible delay that allows daylight between its lower tolerance limit and the total clearing time of the motor circuit protector.

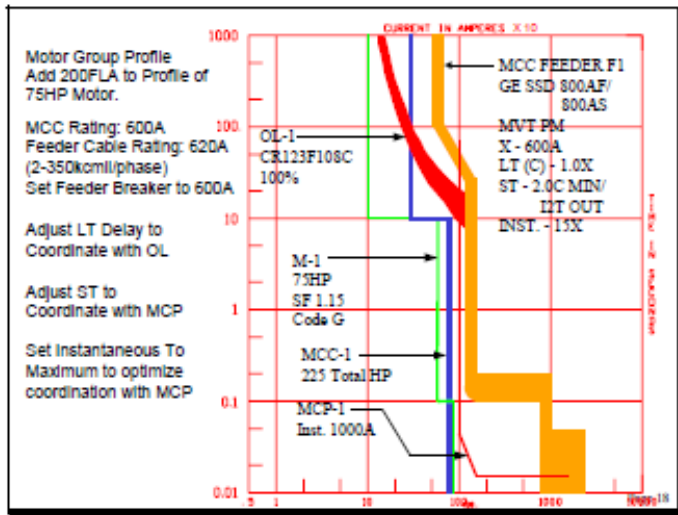

Figure 10 — Adding the feeder breaker supplying the motor control center

The instantaneous setting of the feeder breaker is then selected. If selectivity between the feeder breaker and downstream short-circuit devices is to be maximized, the maximum instantaneous setting is selected. However, there may be circumstances that dictate a lower setting. A feeder instantaneous setting at maximum might prove problematic with the settings of devices upstream of the feeder. This may not be immediately foreseeable until the upstream devices are plotted. Sometimes you have to come back and make adjustments to optimize the system.

Another consideration is the arc-flash energy available at the motor control center. Too high an instantaneous setting may allow an undesirably high arc-flash energy, necessitating the use of bulky and uncomfortable personal protective equipment when work in or around live equipment is necessary. Arc-flash calculations should be made following the coordination study to ascertain the arc-energy levels and required classes of personal protective equipment. If the energy levels are too high, an adjustment in the instantaneous settings may help lower the energy levels.

An evaluation of the graph in Figure 10 would conclude that the expected load currents will flow without nuisance tripping. Complete selectivity of overcurrent devices is indicated, with the exception of a potential lack of selectivity between the feeder circuit breaker and the motor circuit protector for currents beginning at about 8,000 amperes and extending to the maximum short circuit of about 15,000 amperes, indicated by the end of the motor circuit protector curve.

## Unit Substation and Primary Device Settings

It is difficult to plot much more than six curves on a time-current graph before it starts getting crowded or you run out of room on the graph. In order to plot successive devices, we have transferred the curve of the feeder breaker onto a new graph (Figure 11). The multiplier of the current scale is one factor of ten higher to allow us to plot the necessary upstream devices completely.

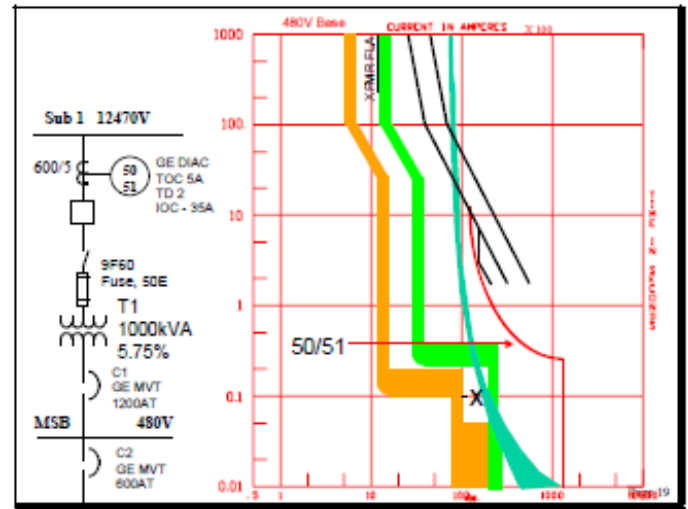

Figure 11 — Unit substation settings

In this example, the feeder we just plotted happens to have the highest settings of all the feeders in the substation. The settings of the main will be coordinated to it. Since all the other feeders have the same or lower settings, they will all coordinate to the main also because their curves must be to the left or below that of the highest set feeder.

The main breaker serves multiple functions. It provides overload and short circuit protection for the substation bus, and backup short circuit protection for the feeders. It is also the primary overload protection for the 1000 kVA transformer. The switchgear is close coupled to the secondary of the transformer which minimizes the risk of short circuits on the conductors between the transformer and the switchgear. This allows the main breaker to be considered along with the primary fuse in assessing the transformer's protection against damage from through-faults.

The transformer through-fault curve is plotted on this graph. Proper protection of this curve is obtained when the protective devices are below or to the right of the withstand curve. Another key piece of transformer information is the inrush current, typically plotted as a point at 0.1 second. An "X" indicates the estimated inrush current at 0.1 second. Primary overcurrent device curves must be above or to the right of this point to assure that nuisance tripping will not occur upon energizing the transformer. Secondary protective device curves do not apply because the inrush current flows only through the primary devices.



Determining the main settings uses very much the same methodology as the feeder settings. As always, we want the main curve to be above and or to the right of the feeder's curve. There should be daylight between the curves and no crossing or overlapping if at all possible. The main breaker uses the same type of trip device as the feeder. The curves are very similar and can allow for very close coordination.

The current setting of the main is set to the current rating of the switchgear main bus to allow full load current to flow. While actual load conditions may allow a lower setting, the ampacity of the bus is used so that the main breaker settings do not have to be reevaluated each time load is added to the substation. Since the main breaker is also part of the transformer secondary protection, the maximum current setting of the main must also comply with the maximum secondary settings dictated by the National Electrical Code. If this setting does not match the bus rating, the breaker must be set to whichever one is less.

The long-time delay is set as low as possible while maintaining daylight between it and the feeder long-time curve. The short-time pickup is also set to the lowest possible setting that maintains selectivity with the feeder. The selected short time delay is the next longer delay band available.

The type of breaker selected for this main must have an instantaneous setting. The instantaneous on the main is set to its maximum to reduce the range of currents where the instantaneous trips of the main and feeder overlap. Again, an evaluation of arc-flash energies at the substation may dictate a lower setting instead, and selectivity is compromised in exchange for improved personnel safety.

The transformer primary fuse is shown on the plot. Note that it does not entirely protect the transformer against through-faults, as indicated by the crossing of the fuse curve over the withstand curve at approximately 8,000 amperes. This should not be a big concern since the main breaker is also a significant part of the withstand protection and its position with respect to the withstand curve indicates that adequate protection is provided. Notice that the fuse curve crosses over the main breaker curve and then crosses back. This indicates a nonselective range of currents where the primary fuse may or will blow before the main breaker trips. Since there are no power tap-offs between the fuse and the breaker, the same amount of the power system will have an outage regardless of which one isolates the current. It would still be preferable for the main breaker to trip first for several reasons. A blown fuse would focus attention on the transformer, which may not be the actual fault location. High voltage fuses are expensive, and it costs nothing to reset a circuit breaker and restore voltage to the load once the source of the fault is resolved and repaired.

A time-overcurrent relay is also plotted. An adequate time margin between the relay and the fuse curve must be maintained along the entire portion of the time curve. The GE DIAC relay illustrated is a digital relay. This allows the time margin to be as low as 0.20 second when using a 5-cycle breaker. Since this relay is coordinating with a fuse and not an induction disk relay, the 0.1 second margin for overtravel need not be considered. The knee created by the intersection of the main short-time delay band and its instantaneous

pickup can be ignored when evaluating coordination with the relay because the primary fuse will blow before current actuates this portion of the breaker curve.

## Conclusions

Using time-current curves as a graphical technique to illustrate selective coordination makes it easy to demonstrate whether or not selectivity has been obtained by the device settings and whether they adequately protect the distribution equipment. Once you become accustomed to reading these curves the system evaluation can be done quickly.

---

## References

- [1] M. E. Valdes, I. Purkayastha, and T. Papallo, "The Single-Processor Concept For Protection And Control Of Circuit Breakers In Low-Voltage Switchgear," *IEEE Trans. Ind. Appl.*, vol. 40, no. 4, pp. 932 – 940, July-Aug. 2004

---

Gary H. Fox, PE, received his BSEE from California Polytechnic State University, San Luis Obispo in 1978. He has been employed by General Electric Company for 31 years. His current assignment is a Senior Specification Engineer for GE Consumer & Industrial in Concord, CA, providing application and technical support for power distribution/control equipment and lighting. Previous assignments included experience in field testing and maintenance of power equipment, project management, and power system analysis. Mr. Fox is a Senior Member of the IEEE Industry Applications (IAS) and IEEE Power Engineering Societies. He has authored several IEEE papers on protective relay application and surge protection, and was a recipient of the IEEE Third Millennium Medal. He is actively participating in several IEEE working groups responsible for developing recommended practices for the design of industrial and commercial power systems.